

SOLAR INVERTERS

ABB central inverters

ULTRA-700.0/1050.0/1400.0/1500.0-TL OUTD

780 to 1560 kW



01

—
01
ULTRA-1500.0-TL

The new liquid-cooled, high-powered ULTRA-1500.0 unit is designed with large utility-grade installations in mind.

This large inverter system significantly reduces the wiring requirements and on-site testing thanks to the presence of separated and dedicated compartments for DC and AC.

Up to four independent MPPT input channels for maximum flexibility and energy harvesting

Up to four, independent Maximum Power Point Tracking (MPPT) input channels offer maximum flexibility and energy harvesting.

The compact chassis gives maximum power for the minimum footprint and the outdoor enclosure enables unrestricted use under any environmental conditions.

ABB's ULTRA utility-scale inverters optimize energy harvesting across a wide array of operating conditions with their industry-leading power conversion efficiencies of up to 98.7% combined with their high-speed Maximum Power Point Tracking (MPPT) channels.

Highlights

- Maximum DC input voltage up to 1000 V, high design flexibility and reduced DC distribution losses for large-scale PV plants
- Reduced susceptibility to a single fault; in case of a component failure, a maximum of 350 kW will be lost
- Integrated DC and AC distribution and protection; fully equipped for connection, additional accessories not required
- Direct transformerless conversion to the 690 Vac output reduces AC distribution cost
- Extended MPPT input voltage range
- Liquid cooling with total segregation of internal compartments assuring a 5-year maintenance cycle
- Easy installation and maintenance procedure; front extractible DC/AC converters and accessibility to all critical parts
- Two independent RS-485 communication interfaces for inverter and intelligent string combiner monitoring
- Compliance to BDEW, FERC 661 and other relevant grid standards allows installation in most of the countries worldwide

ABB central inverters

ULTRA-TL OUTD

780 to 1560 kW



Technical data and types

Type code	ULTRA-700.0-TL	ULTRA-1050.0-TL	ULTRA-1400.0-TL	ULTRA-1500.0-TL
Input side				
Absolute maximum DC input voltage ($V_{max,abs}$)	1000 V			
MPPT input DC voltage range ($V_{MPPTmin} \dots V_{MPPTmax}$) at V_{acr}	470...900 V Linear derating from max to 15 kW [850 V < V_{MPPT} < 900 V] 560 kW @ 470 V	470...900 V Linear derating from max to 22.5 kW [850 V < V_{MPPT} < 900 V] 840 kW @ 470 V	470...900 V Linear derating from max to 30 kW [850 V < V_{MPPT} < 900 V] 1120 kW @ 470 V	470...900 V Linear derating from max to 30 kW [850 V < V_{MPPT} < 900 V] 1120 kW @ 470 V
MPPT input DC range ($V_{MPPTmin} \dots V_{MPPTmax}$) at P_{acr} and V_{acr}	585...850 V @ 700 kW 645...850 V @ 780 kW	585...850 V @ 1050 kW 645...850 V @ 1170 kW	585...850 V @ 1400 kW 645...850 V @ 1560 kW	585...850 V @ 1400 kW 645...850 V @ 1560 kW
Number of independent MPPT multi-master	2	3	4	4
Maximum combined DC input current (I_{dcmaxc})	1388 A (2 x 694 A)	2082 A (3 x 694 A)	2776 A (4 x 694 A)	2776 A (4 x 694 A)
Maximum DC input current for each module ($I_{dcmax,m}$)	694 A			
Number of DC inputs pairs	10	15	20	20
DC connection type	20 x 50 mm ² ... 240 mm ² (M12)	30 x 50 mm ² ... 240 mm ² (M12)		40 x 50 mm ² ... 240 mm ² (M12)
Input protection				
Reverse polarity protection	Yes			
Input overvoltage protection	Type I voltage surge protection, 1 for each module			Type II voltage surge protection, 1 for each module
Photovoltaic array leakage control, floating neutral, floating panels	Optional			
Residual current protection, grounded neutral, floating panels	Not included; recommended 10 A ground fault protection with time and current adjustable			
Fuse size for each input pair	160...400 A			
Output side				
AC grid connection type	Three-phases 3W+PE			
Rated AC power ($P_{acr} @ \cos\phi=1$)	780 kW	1170 kW	1560 kW	1560 kW
Maximum apparent power (S_{max})	780 kVA	1170 kVA	1560 kVA	1560 kVA
Rated grid voltage (V_{acr})	690 V			
AC voltage range ($V_{acmin} \dots V_{acmax}$)	621...759 V ¹⁾			
Maximum output current (I_{acmax})	650 A	975 A	1300 A	1300 A
Contributory fault current	1036 A	1554 A	2072 A	2072 A
Rated frequency (f_r)	50/60 ⁴⁾ Hz			
Frequency range ($f_{min} \dots f_{max}$)	47...53 / 57...63 Hz ²⁾			
Nominal power factor and adjustable range	> 0.995 (adj. \pm 0.10)			
Total harmonic distortion	< 3% (@ $P_{ac,r}$)			
AC connection type (for each phase)	6 x 240 mm ² (M12)			
Output protection				
Anti-islanding protection	According to local standard			
Output overvoltage protection	Type II voltage surge protection			
AC switch	Yes, AC switch / AC circuit breaker (optional)			
AC fuse for each module	3x450 A / 200 kA			
Operating performance				
Maximum efficiency (η_{max})	98.7% ³⁾			
Weighted efficiency (η_{EURO} / η_{CEC})	98.2% / 98.0% ³⁾			
Stand-by consumption/night-time power loss	< 90 W	< 110 W	< 180 W	< 180 W
AC auxiliary supply	3 x 400 Vac +N, 50/60 Hz			
Auxiliary supply consumption	< 0.50% of $P_{ac,r}$	< 0.60% of $P_{ac,r}$	< 0.50% of $P_{ac,r}$	< 0.50% of $P_{ac,r}$
Auxiliary supply consumption without cooling	< 0.05% of $P_{ac,r}$	< 0.06% of $P_{ac,r}$	< 0.05% of $P_{ac,r}$	< 0.05% of $P_{ac,r}$
Inverter switching frequency	9 kHz			

ABB ULTRA-TL-OUTD central inverter block diagram

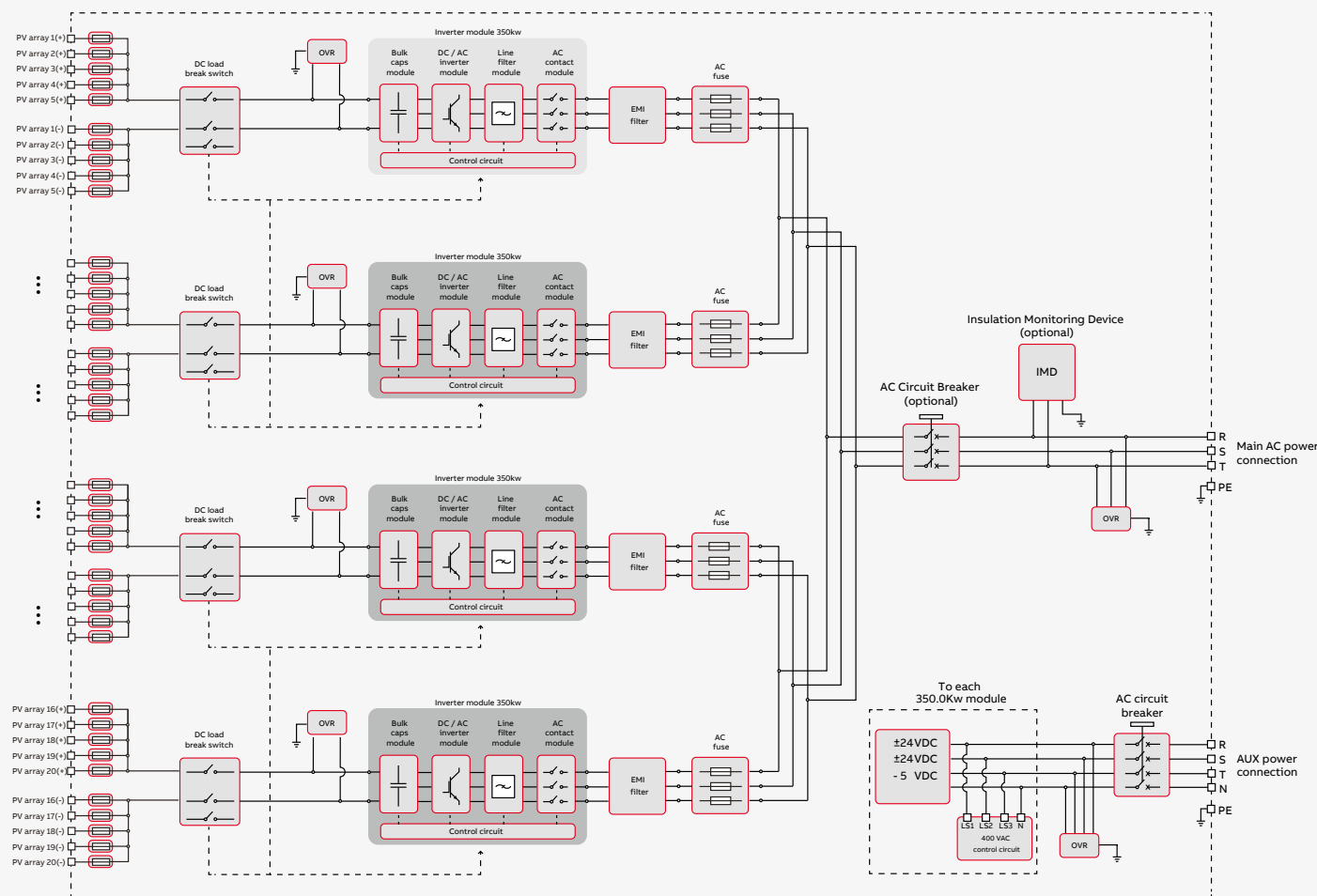

Technical data and types

Type code	ULTRA-700.0-TL	ULTRA-1050.0-TL	ULTRA-1400.0-TL	ULTRA-1500.0-TL
Communication				
Wired local monitoring		PVI-USB-RS232_485 (opt.)		
Remote monitoring		VSN700 Data Logger (opt.)		
String Combiner		PVI-STRINGCOMB (opt.)		
User interface		TFT LCD 5.7"		
Environmental				
Ambient temperature range	-20...+ 60°C/-4...140°F with derating above 50°C/122°F			
Relative humidity	0...100% condensing			
Sound pressure level, typical	78 dB(A) @ 1 m			
Maximum operating altitude without derating	2000 m / 6560 ft			
Physical				
Environmental protection rating	IP65	IP65	IP65	IP54
Cooling	Liquid cooling with on-board heat exchanger			
Required air cooling flow	Not applicable			
Dimension (H x W x D)	2920 x 3020 x 1520 mm / 114.9 x 118.9 x 59.9"	2920 x 3720 x 1520 mm / 114.9 x 146.5 x 59.9"	2920 x 4420 x 1520 mm / 114.9 x 174.0 x 59.9"	2734 x 4840 x 1128 mm / 107.64 x 190.55 x 44.41"
Weight	< 3000 kg / 6613 lbs	< 3800 kg / 8377 lbs	< 4600 kg / 10141 lbs	< 4000 Kg / 8818 lbs
Weight of the module	< 55 kg / 121 lbs			
Safety				
Transformer	No			
Marking	CE (50 Hz only)			
Safety and EMC standard	EN 50178, IEC/EN 62109-1, IEC/EN 62109-2, EN61000-6-2, EN61000-6-4			
Grid standard (check your sales channel for availability)	CEI-0-16, BDEW, P.O.12.3, Ordinul 30/2013			

¹⁾ The AC voltage range may vary depending on specific country grid standard

²⁾ The Frequency range may vary depending on specific country grid standard

Remark. Features not specifically listed in the present data sheet are not included in the product For the available options refer to the configuration module and verify with ABB technical support

³⁾ Power consumption of the auxiliary services not included

⁴⁾ Check availability with ABB

Efficiency curves of ULTRA-TL-OUTD

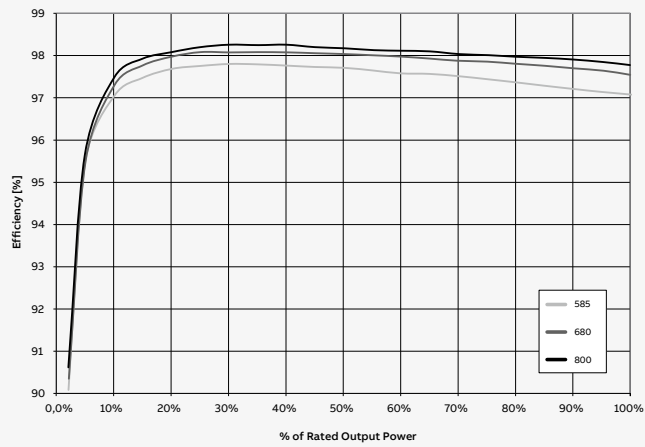

For more information please contact your local ABB representative or visit:

www.abb.com/solarinverters
www.abb.com

We reserve the right to make technical changes or modify the contents of this document without prior notice. With regard to purchase orders, the agreed particulars shall prevail. ABB AG does not accept any responsibility whatsoever for potential errors or possible lack of information in this document.

We reserve all rights in this document and in the subject matter and illustrations contained therein. Any reproduction, disclosure to third parties or utilization of its contents – in whole or in parts – is forbidden without prior written consent of ABB AG. Copyright© 2017 ABB
 All rights reserved

